

PLAN

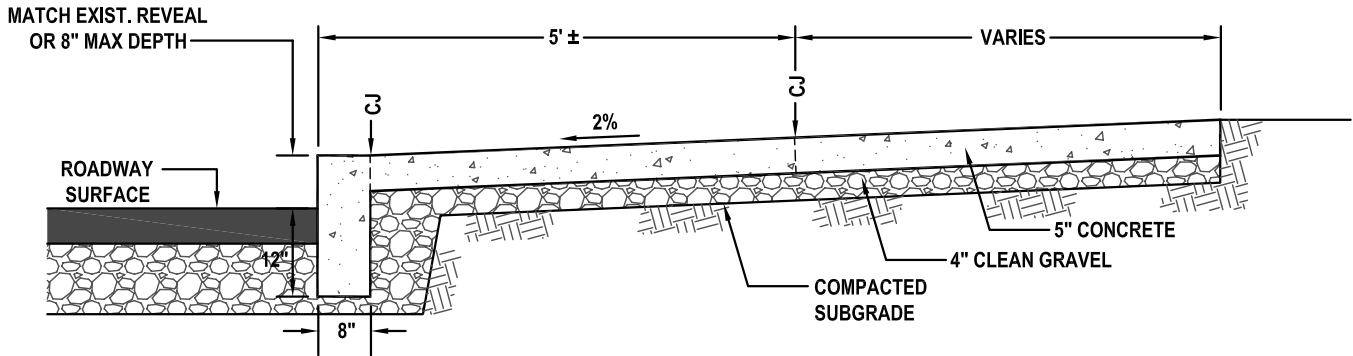

**SECTION
MONOLITHIC CURB & 5" SIDEWALK**

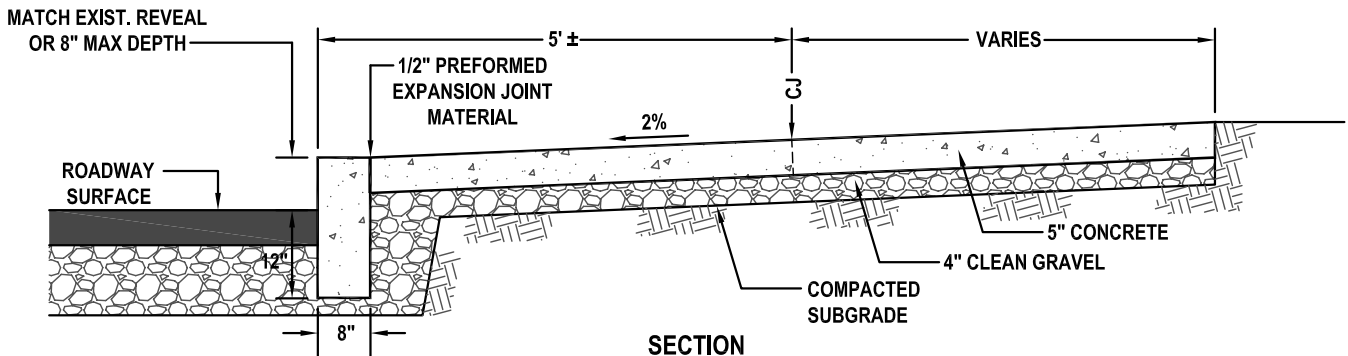

**SECTION
STRAIGHT 8" CURB W/ 5" SIDEWALK**

CONSTRUCTION NOTES:

- Strike control joints every 4'-0" and place expansion joints every 16'-0".
- Install 1/2" preformed expansion joint material at all expansion joints and where sidewalk abuts concrete curb, foundations, aprons, or other concrete structures.
- All concrete construction shown on these standard details shall use 3000 P.S.I. SHA Mix No. 2 concrete unless otherwise specified.
- All storm drain structures shall be underlain with a minimum 6" clean crushed stone base.

APPROVED:

DIRECTOR

DATE

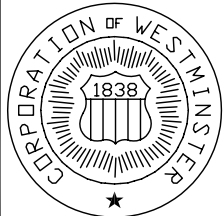

No.	REVISIONS	DATE

**CITY OF WESTMINSTER
DEPARTMENT OF PUBLIC WORKS
STANDARDS FOR SIDEWALK & ENTRANCE CONSTRUCTION**

**CURB & SIDEWALK RECONSTRUCTION
SIDEWALK AGAINST CURB**